



Product Brochure



**WOMBAT**

- Compact Electric Lifting Machine
- **140kg capacity**
- Electric lifting and manual foot pedal opening
- Rechargeable battery supplied with separate charger
- 3 lifting frame options including the standard tilting cradle, yoke bar or power tilt cradle (electric)
- The power tilt cradle option reduces manual handling, risk of injuries and assists with correct positioning of patient
- Optional scale attachment allows for weighing easily and accurately
- Ideal for aged care facilities and in the home
- 2 year warranty
- Variety of sling options available



**JOEY**

- Electric Lifting Machine
- **200kg capacity**
- Electric lifting and leg opening control
- Rechargeable battery supplied with separate charger
- 3 lifting frame options including the standard tilting cradle, yoke bar or power tilt cradle (electric)
- The power tilt cradle option reduces manual handling, risk of injuries and assists with correct positioning of patient
- Optional scale attachment allows weighing easily and accurately
- Ideal for hospitals and aged care facilities
- 2 year warranty
- Variety of sling options available



Power Tilt Cradle  
(Wombat, Joey, Jumbuck)



Stretcher Frame Attachment  
& Stretcher Frame (Jumbuck)



Weigh Scale  
(Wombat, Joey, Jumbuck)



Walking Hanger Bar &  
Handles (Jumbuck)



Yoke Bar  
(Wombat, Joey, Jumbuck)

**AVAILABLE HAYCOMP LIFTER ACCESSORIES**

Contact AIS Healthcare  
for product brochure  
trial and staff training  
**03 9729 9399**



**JUMBUCK 240**

- Electric Bariatric Lifting Machine
- **240kg capacity**
- Electric lifting and leg opening control
- Rechargeable battery supplied with separate charger
- 3 lifting frame options including the standard tilting cradle, yoke bar or power tilt cradle (electric)
- The power tilt cradle option reduces manual handling, risk of injuries and assists with correct positioning of patient
- Optional scale attachment allows for weighing easily and accurately
- Optional stretcher frame attachment and stretcher frame allows for horizontal lifts
- Optional walking handles provides walking feature
- Ideal for hospitals and aged care facilities
- 2 year warranty
- Variety of sling options available

**JUMBUCK 300**

- Electric Bariatric Lifting Machine
- **300kg capacity**
- Electric lifting and leg opening control
- Rechargeable battery supplied with separate charger
- Standard 4 point hanger attachment designed to work with Bariatric sling for patients between 240-300kg range
- The power tilt cradle option reduces manual handling, risk of injuries and assists with correct positioning of patient
- Fully compatible with all Jumbuck 240 range of accessories including standard cradle, power tilt cradle (electric), stretcher frame and rehab walking accessories
- Optional scale attachment allows for weighing easily and accurately
- Ideal for general and bariatric care
- 2 year warranty
- Variety of sling options available (dependent on attachment)

	WOMBAT	JOEY	JUMBUCK 240	JUMBUCK 300
	Compact Electric Lifter	Electric Lifter	Electric Bariatric Lifter	Electric Bariatric Lifter
Capacity	140kg	200kg	240kg	300kg
Leg Opening	Foot Pedal	Electric Control	Electric Control	Electric Control
Base Height (inc. Castor)	140mm	140mm	140mm	150mm
Base Width	650mm	650mm	650mm	750mm
Base Length	1100mm	1100mm	1250mm	1300mm
Leg Width (Closed)	540mm	540mm	540mm	580mm
Leg Width (Open)	1040mm	1040mm	1240mm	1200mm
Unit Height	1350mm	1370mm	1660mm	1660mm
Lifter Mass	45kg	50kg	57kg	60kg
Castor Size	100mm	100mm	100mm	100mm

Accessories Code	Wombat	Joey	Jumbuck 240	Jumbuck 300
Cradle Attachment	HC15-07000	HC01-07000	HC07-07000	HC07-07000 (240kg Capacity)
Power Tilt Cradle	HC01-10000	HC01-10000	HC07-10000	HC07-10000 (240kg Capacity)
Yoke Attachment	HC15-08000	HC01-08000	HC07-08000	HC07-08000 (240kg Capacity)
Stretcher Frame Attachment			HC07-09000	HC07-09000
Weigh Scale (Fitted to lifter)	HC15-12000	HC01-12000	HC07-14000	HC30-1400
Walking Aid				
Walking Handles			HC07-1600	HC07-1600
Walking Hanger Bar			HC07-1500	HC07-1500



**BOOMER**

- Electric Bariatric Lifter
- **350kg capacity**
- Electric lifting and leg opening control
- Rechargeable battery supplied with separate charger
- Standard 4 point hanger attachment designed for use with Boomer bariatric slings
- Extra wide base for stability and wide handles to accommodate 2 operators
- Ideal for bariatric care
- 2 year warranty
- Boomer sling available in different sizes

	BOOMER
Capacity	350kg
Leg Opening	Electric Control
Base Height	155mm
Base Width	980mm
Base Length	1410mm
Leg Width (Closed)	810mm
Leg Width (Open)	1530mm
Unit Height	1400mm
Lifter Mass	85kg
Castor Size	100mm



**EMU**

- Standing / Walking Machine
- **175kg capacity**
- Electric lifting and leg opening control
- Rechargeable battery supplied with separate charger
- Emu stander facilitates the transfer from bedside to chair, commode or toilet
- The foot plate can be pivoted upward behind the knee pad to convert the Emu stander into a walker for patients who are weight bearing and require minimal assistance
- The addition of rehab arms convert the Emu into a rehab walker with full patient support
- Ideal for hospital and aged care facilities
- 2 year warranty
- Variety of sling options available



**BILBY**

- Lightweight, Compact Standing Transfer Hoist
- **200kg capacity**
- Electric lifting and leg opening control
- Rechargeable battery supplied with separate charger
- Shorter legs for greater manoeuvrability in confined spaces
- Deep knee pad provides maximum comfort and eliminates slippage
- High lift to stand resident upright on foot plate
- Ideal for hospital and aged care facilities
- 2 year warranty
- Variety of sling options available

	EMU	BILBY
	Walker	Standing Transfer Hoist
<b>Capacity</b>	175kg	200kg
<b>Leg Opening</b>	Electric Control	Electric Control
<b>Base Height</b>	140mm	140mm
<b>Base Width</b>	650mm	650mm
<b>Base Length</b>	1100mm	1000mm
<b>Leg Width (Closed)</b>	520mm	520mm
<b>Leg Width (Open)</b>	1070mm	1070mm
<b>Unit Height</b>	1470mm	1370mm
<b>Lifter Mass</b>	73kg	51kg
<b>Castor Size</b>	100mm	100mm



Emu Rehab Option (Available for both new purchases or as an addition to your existing Emu)

Emu Rehab Arm & Emu Rehab Sling

Emu Rehab Arms	HC12-10000
----------------	------------



**Fabric Options**

- 100% Polyester Mesh - flow through fabric suitable for all round use and ideal for use in water where quick draining and drying is important
- 100% Nylon (Solid) - for strength and comfort suitable for all round use
- Slings are fully washable and quick drying. Slings come with correct washing instructions and manufacturers instructions
- It is highly recommended that slings be washed using the Washing Bag to protect the sling and prolong its life
- Slings are tested to International Standards ISO/DIS 10535

**Emu/Bilby Standard Sling**

- For use with the EMU or BILBY Patient Standing Transfer Hoists • S.W.L 200kgs

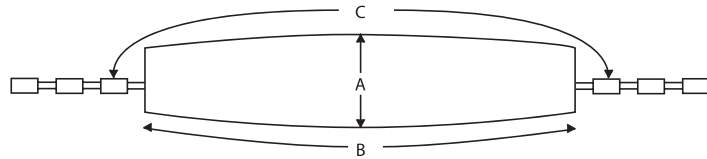

Size	Product Code		Dimension		
	Nylon with Velcro Fastening	Nylon with Buckle Fastening	A (Height)	B (Length)	C (From 1st clip LHS to 1st clip RHS)
S	HC02-0600S	HC02-0650S	250mm	1200mm	1400mm
M	HC02-0600M	HC02-0650M	250mm	1300mm	1500mm
L	HC02-0600L	HC02-0650L	250mm	1400mm	1600mm
XL	HC02-0600XL	HC02-0650XL	250mm	1500mm	1700mm

**Emu/Bilby Leg Strap**

- For use with the EMU or BILBY Patient Standing Transfer Hoists

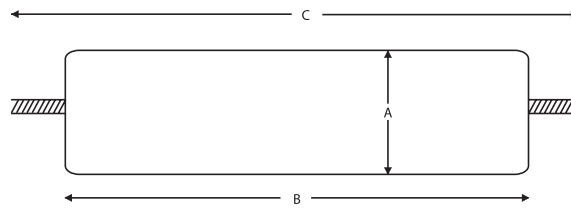

Size	Product Code		Dimension		
	Nylon	A (Height)	B (Length)	C (Longest Clip to Clip Length)	
One Size	HC02-08000	125mm	450mm	1090mm	

**Emu Rehab Sling - chest sling to support patient in a standing/walking position**

- For use with the EMU Standing Machine fitted with the Rehab Arm Accessory (for walking/rehab) • S.W.L 175kgs

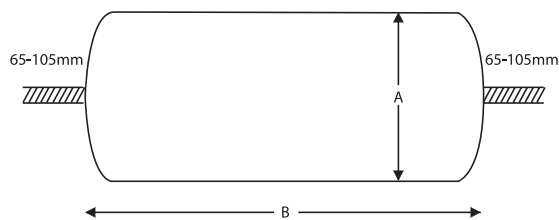

Size	Product Code	Dimension			
		A (Waist Pad Height)	B (Waist Pad Length)	To Fit Approx Waist Size	To Fit Chest Size
S	HC12-1200S	290mm	750mm	700-1050mm	700-1000mm
M	HC12-1200M	290mm	920mm	800-1200mm	800-1200mm
L	HC12-1200L	290mm	1100mm	1000-1400mm	1000-1400mm
XL	HC12-1200XL	290mm	1300mm	1200-1600mm	1200-1600mm

### Jumbuck Walking Sling - chest sling to support patient in a standing/walking position

- For use with the Jumbuck Patient Lifting Machine fitted with the Walking Accessories • S.W.L 240kgs

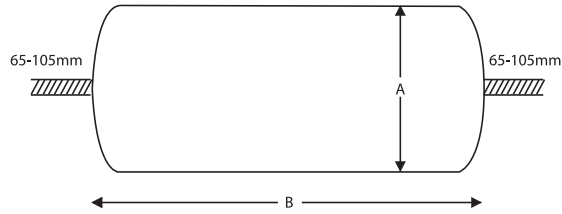

Size	Product Code	Dimension		
		A (Waist Pad Height)	B (Waist Pad Length)	To Fit Waist Size
S	HC07-1800S	290mm	750mm	700-1050mm
M	HC07-1800M	290mm	920mm	800-1200mm
L	HC07-1800L	290mm	1100mm	1000-1400mm
XL	HC07-1800XL	290mm	1300mm	1200-1600mm

### Standard Cradle Sling - full body sling with head support and back support

- For use with the WOMBAT, JOEY & JUMBUCK Patient Lifting Machines • Cradle Attachment required • S.W.L 240kgs

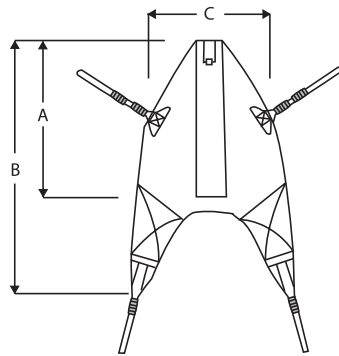

Size	Product Code		Dimension		
	Nylon	Mesh	A	B	C
S	HC01-0900S	HC01-0950S	880mm	1350mm	750mm
M	HC01-0900M	HC01-0950M	950mm	1400mm	800mm
L	HC01-0900L	HC01-0950L	1060mm	1510mm	940mm
XL	HC01-0900XL	HC01-0950XL	1090mm	1620mm	1000mm

### Cradle Sling Toileting - with head support and back support

- For use with the WOMBAT, JOEY & JUMBUCK Patient Lifting Machines • Cradle Attachment required • S.W.L 240kgs

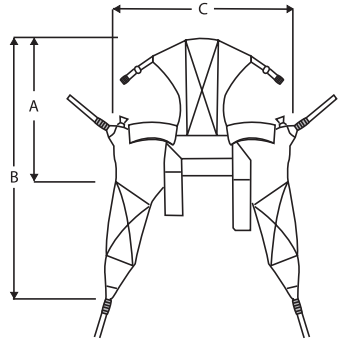

Size	Product Code		Dimension		
	Nylon	Mesh	A	B	C
S	HC01-1200S	HC01-1250S	720mm	1250mm	900mm
M	HC01-1200M	HC01-1250M	750mm	1330mm	1000mm
L	HC01-1200L	HC01-1250L	800mm	1450mm	1120mm
XL	HC01-1200XL	HC01-1250XL	850mm	1550mm	1200mm

### Cradle Sling Toileting - soft back without head support

- For use with the WOMBAT, JOEY & JUMBUCK Patient Lifting Machines • Cradle Attachment required • S.W.L 240kgs

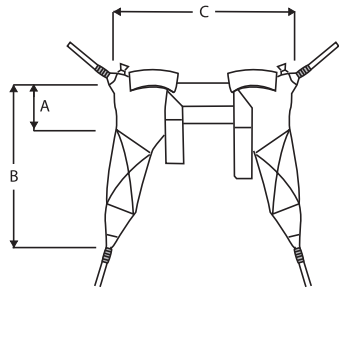

Size	Product Code		Dimension		
	Nylon	Mesh	A	B	C
S	HC01-1400S	HC01-1450S	300mm	850mm	900mm
M	HC01-1400M	HC01-1450M	300mm	900mm	1000mm
L	HC01-1400L	HC01-1450L	300mm	970mm	1120mm
XL	HC01-1400XL	HC01-1450XL	300mm	1040mm	1200mm

### All Day Sling - soft back for all day use without head support

- For use with the WOMBAT, JOEY & JUMBUCK Patient Lifting Machines • Cradle Attachment required • S.W.L 240kgs

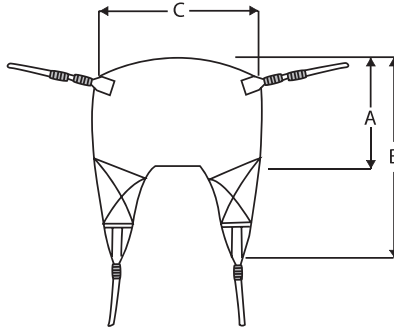

Size	Product Code		Dimension		
	Nylon	Mesh	A	B	C
S	HC01-1300S	HC01-1350S	500mm	1000mm	750mm
M	HC01-1300M	HC01-1350M	550mm	1030mm	800mm
L	HC01-1300L	HC01-1350L	610mm	1150mm	900mm
XL	HC01-1300XL	HC01-1350XL	650mm	1180mm	1000mm

### All Day Sling - soft back for all day use with head support

- For use with the WOMBAT, JOEY & JUMBUCK Patient Lifting Machines • Cradle Attachment required • S.W.L 240kgs

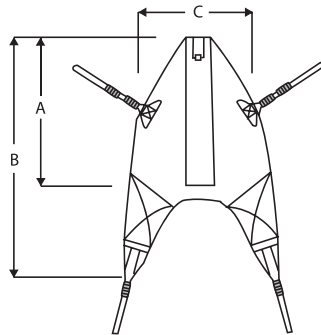

Size	Product Code		Dimension		
	Nylon	Mesh	A	B	C
S	HC01-1500S	HC01-1550S	880mm	1350mm	750mm
M	HC01-1500M	HC01-1550M	950mm	1400mm	800mm
L	HC01-1500L	HC01-1550L	1060mm	1510mm	940mm
XL	HC01-1500XL	HC01-1550XL	1090mm	1620mm	1000mm

### Cradle Amputee Sling - with head support and thigh & chest straps (available without head support)

- For use with the WOMBAT, JOEY & JUMBUCK Patient Lifting Machines • Cradle Attachment required • S.W.L 240kgs

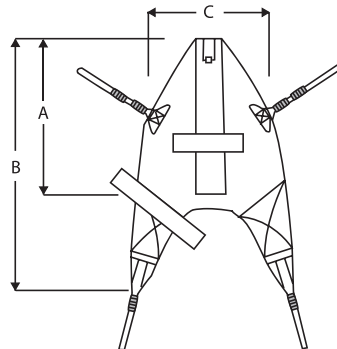

Size	Product Code		Dimension		
	Nylon	Mesh	A	B	C
S	HC01-1700S	HC01-1750S	880mm	1210mm	750mm
M	HC01-1700M	HC01-1750M	930mm	1270mm	790mm
L	HC01-1700L	HC01-1750L	1030mm	1420mm	940mm



**Boomer Sling - bariatric sling with soft back (nylon only)**

- For use with the JUMBUCK & BOOMER Patient Lifting Machines • 4 Point Hanger Bar Attachment required • S.W.L 350kgs

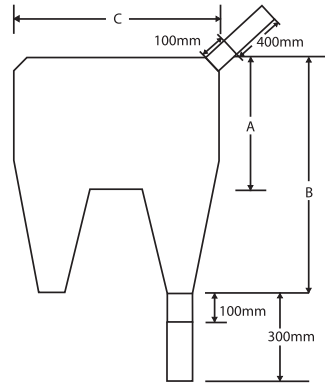

Size	Product Code	Dimension		
		A	B	C
M	HC20-0300M	800mm	1600mm	1400mm
L	HC20-0300L	800mm	1700mm	1750mm

**General Purpose Sling - soft back without head support (also available with head support)**

- For use with the WOMBAT, JOEY & JUMBUCK Patient Lifting Machines • Yoke Bar Attachment required • S.W.L 200kgs

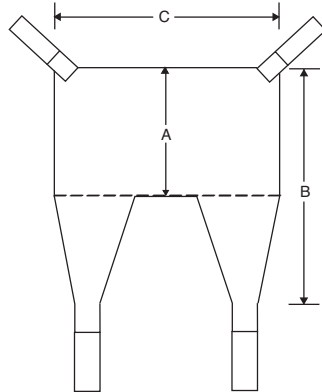

Size	Product Code		Dimension		
	Nylon	Mesh	A	B	C
S	HC01-1000S	HC01-1050S	530mm	990mm	740mm
M	HC01-1000M	HC01-1050M	570mm	1170mm	840mm
L	HC01-1000L	HC01-1050L	650mm	1350mm	870mm
XL	HC01-1000XL	HC01-1050XL	680mm	1400mm	980mm

**General Purpose Toileting Sling - soft back without head support (also available with head support)**

- For use with the WOMBAT, JOEY & JUMBUCK Patient Lifting Machines • Yoke Bar Attachment required • S.W.L 175kgs

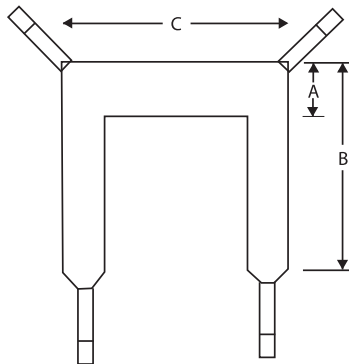

Size	Product Code		Dimension		
	Nylon	Mesh	A	B	C
S	HC01-1100S	HC01-1150S	280mm	900mm	750mm
M	HC01-1100M	HC01-1150M	300mm	1020mm	850mm
L	HC01-1100L	HC01-1150L	300mm	1120mm	900mm
XL	HC01-1100XL	HC01-1150XL	320mm	1220mm	1000mm

**General Purpose Amputee Sling - no head support (available with head support) with toileting hole (available without toileting hole)**

- For use with the WOMBAT, JOEY & JUMBUCK Patient Lifting Machines • Yoke Bar Attachment required • S.W.L 175kgs

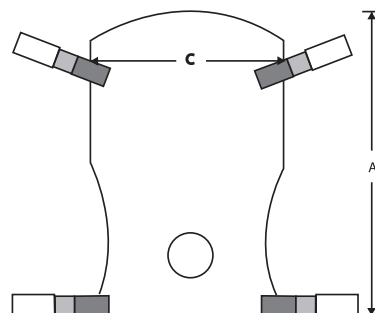

Size	Product Code	Dimension	
		A	C
S	HC01-1950S	1250mm	550mm
M	HC01-1950M	1300mm	650mm
L	HC01-1950L	1400mm	750mm
XL	HC01-1950XL	1450mm	850mm



**TR Height Adjustable Bath  
TR 900CWA (Cleaning, Whirlpool & Autofill)**

**Ergonomic design**

Ergonomically designed, the bathtub is height adjustable by hand control, simple and convenient for attendant to operate. The extra width of the bathtub at the head end allows more space for arms and shoulders and is an advantage when shampooing

**Cleaning**

Separate cleaning system located at the side and rear of the bathtub. Hidden and activated with a safety on/off key

**Whirlpool**

Whirlpool function allows regulations of both jet direction and quantity of air. The relaxing whirlpool effect stimulates the circulation and assists with washing the patient

**Autofill**

The one touch unattended Autofill water system allows prefilling of the bathtub while patient is preparing for bathing. Temperature is set with the thermostatic mixing valve. If required, additional water can be added when the pre-set Autofill level is reached

**Thermometer**

Clear thermometer showing temperature of shower and filling water flows

**Durable**

The bathtub is made of double fiberglass and durable materials which minimises water heat loss and extends the product lifetime

**Efficient bathing cycle**

Suitable to use with the TR 9650 Bath Lift System or other patient lift, mobile or ceiling hoist systems, providing safe moving and handling for both patient and attendant

	TR 900CWA
Length	2325 mm
Width	830 mm
Working Load Limit	150 kg
Operating Height Range	600-1000mm
Power Supply	230 V 50 Hz

**TR Height Adjustable Bath  
TR 1700**

**Optimal size**

Specially designed to optimize your small space without sacrificing function and efficiency. Ideal for hospitals, nursing homes and private homes who have limited space and require a fully functioning bathtub

**Height adjustment**

The bathtub can be safely and easily raised and lowered to suit the ideal working height for the attendant, reducing the risk of heavy lifting and bending, fatigue and risk of back injury

**Thermostat**

The factory mounted thermostat regulates both the bathtub filling and shower water temperature

**Hygienic emptying**

A pop-up drainage closes and opens by turning the overflow valve. No hands need to be in water

**Adjustable feet**

Adjustable feet increases safety and comfort when there are uneven floor surfaces

**Efficient bathing**

Clearance below the tub allows the use of TR 9650 Bath Lift System or other patient lift, mobile or ceiling hoist systems, providing safe moving and handling for both patient and attendant



	TR 1700
Length	1685 mm
Width	695 mm
Height	660-960 mm
Working Load Limit	150 kg
Control	Hand control for height adjustments
Power Supply	230 V 50 Hz

**TR Wellness Bath  
TR Comfortline II**

**Wellness experience**

Designed to offer more than just a bath. The Wellness options make bathing in the TR Comfortline II a relaxing and a "wellness" experience for both the body and mind. Bathing is enhanced with the optional Air Spa to stimulate blood circulation and provide a calming environment, music sound wave system via MP3 smart card, and the LED colour light system that changes the water into different colours creating a soothing effect

**Ergonomic design**

Ergonomically designed, the bathtub is height adjustable by hand control, easy and convenient for attendant to operate. It can also be positioned in any central bathing areas or bathrooms

**Easy Operation**

Easy to understand, operate, clean and maintain thanks to a simple design

**Thermostat**

Thermostatic mixer with temperature limit

**Foot support**

Wide stainless steel legs with foot support adjustable in three positions and removable for comfort and when using bath stretchers

**Efficient bathing cycle**

Suitable to use with the TR 9650 Bath Lift System or other patient lift, mobile or ceiling hoist systems, the Comfortline II is easily accessible from either side or the end of the bathtub



	TR Comfortline II
Length	2080 mm
Width	780 mm
Working Load Limit	150 kg
Lift Speed	8mm/s
Operating Height Range	650-1000 mm
Power Supply	230 V 50 Hz
Overall Weight (empty)	approx 100kg
Water Volume	approx 180 litres



TR 2000

**TR Standard Shower Trolley**  
**TR 2000 - Hydraulic operated**  
**TR 3000 - Battery operated**

The unique side mounting column allows the trolley stretcher to overlap the bed further allowing for a safe and easy transfer

- Easy to transfer, operate and multi task
- Quiet and smooth operation
- Either direction tilting function
- Standard with mattress and pillow
- Durable and easy clean

**Transfer and operation**

Easy to operate, efficient and safe person transfer, transport and showering

**Multi tasking**

Trolley can be used for patient in all types of care environments for showering and other purposes such as dressing and nursing

**Mattress and pillow**

The shower trolley is supplied with standard grey colour durable mattress and pillow which can be cleaned easily

**Foot operated height adjustment - TR 2000**

The foot operated height adjustments stretcher enables the attendant to work efficiently with both hands free to tend the patient

**Hand held control height adjustment - TR 3000**

Operate easily with the hand held control. The stretcher can be raised, lowered and tilted easily and quietly by the actuator powered by rechargeable battery

**Foldable side rails**

The unique offset base design combined with the foldable side rails allow the attendant to position the shower trolley overlapping the bed. The side rails can then be folded all the way down for safe and efficient transfer of the patient

**Easy to steer and manoeuvre**

The large castors with brakes, low angled legs with straight steering castors make the trolley easy to steer and manoeuvre

**Tilting of stretcher**

The stretcher can be tilted in both directions for “Tredelenburg” position and has drainage at both ends allowing the person to be positioned in either direction

**Durable**

The trolley is made of durable material, powder coated stainless steel and zinc plated steel, making cleaning simple and efficient

	TR 2000	TR 3000
Length	TR 2000/TR 3000 (Standard) - 1900mm (Stocked item)	
	TR 2000-S/TR 3000-S (Pediatric) - 1600mm (Non stocked item)	
	TR 2000-L/TR 3000-L (Long) - 2100mm (Non stocked item)	
Width	705 mm	
Height	625-925 mm	
Working Load Limit	150 kg	
Chassis	Powder coated stainless and zinc plated steel	
Castors	Two 100mm castors with brakes and two 75mm with straight steering	
Height Adjustment Control	Foot Control	Electric hand control
Mattress	Flame retardant material (Grey)	
Pillow	Standard	
Power Operation	Hydraulic operation	Rechargeable battery 24 V



TR 4200

**TR Bariatric Shower Trolley**  
**TR 4000 Atlas**  
**TR 4200 Atlas Junior**

Designed with lots of power and loads of space for the Bariatric patient  
 The TR Bariatric shower trolleys are specially designed with a higher working load but with the same attention to quality and efficiency

- Easy to transfer, operate and multi task
- Comes standard with mattress and pillow
- Durable and easy clean

**Higher capacity**

Designed to handle Bariatric patients with higher capacity (270kg or 450kg) in a safe and efficient manner

**Plenty of stretcher space**

The wider stretcher allows plenty of body space convenient both for patient and attendant

**Hand held control**

Operate easily with the hand held control, the stretcher can be raised and lowered easily and quietly by the actuators powered by the rechargeable battery

The hand held control also operates the power tilt in both directions for improved drainage and tilts to a "Trendelenburg" position when desired

**Foldable side rails**

The side rails swing down for transfer and lock into up position for a secure transport

The head end rails can be folded to the horizontal position for extra length

**Foot controlled settings**

Convenient single central foot control for straight steering and brakes on all four castors

**Rubber bumper wheels**

The stretcher has rubber bumper wheels on 4 corners to protect walls and doorways

	TR 4200 Atlas Junior	TR 4000 Atlas
Length	2150 mm	2210 mm
Width	740 mm	915 mm
Height	535-835 mm	
Working Load Limit	270 kg	450 kg
Chassis	Powder coated and zinc plated steel	
Castors	Brakes on all 4 castors and straight steering	
Control	Electric hand control for height adjustments and tilting	
Mattress	Flame retardant material (Grey)	
Pillow	Standard	Backrest wedge pillow 15°
Power Operation	Rechargeable battery 24 V	



**TR Classic Tilt Table**  
**TR Classic**

The TR Classic Tilt Table has been designed to make testing, rehabilitation and transferring patients easier and safer

**Rehabilitation**

A logical choice for rehabilitation patients who benefit from passive standing to improve circulation and reduce lower extremity edema

**Tilt effortlessly**

The TR Classic Tilt Table is electrically operated for smooth and silent operation. It effortlessly tilts from horizontal to a 90° upright position

A hand control is provided for convenient tilt adjustment

**Easy manoeuvring**

Easy manoeuvring thanks to large, locking castors with straight steering

**Safety belts**

Three safety belts ensure patient safety. Adjustable positioning of the belts makes the tilt table suitable for many different patients

**Wide footplate**

Wide footplate, adjustable and lockable in three angle positions for patient comfort and safety

**Activity tray**

Activity tray can be attached to use for reading or other activities

**Back up battery**

Built-in battery backup for lowering in case of a power failure

	TR Classic
Cushion Length - Standard	1750mm (Stocked item)
Cushion Length - Pediatric	1400m (Non stocked item)
Cushion Width - Standard	650mm (Stocked item)
Cushion Width - Pediatric	450mm (Non stocked item)
Height (Horizontal Position)	600mm
Working Load Limit	150kg
Power Supply	230V 50Hz
Power Failure Lowering	Battery backup
Frame	Powder coated steel
Castors	125mm Two castors with brakes and two with straight steering
Control	Hand control for tilt adjustment
Cushion	Foam filled vinyl cover (Grey)



TR 9650 with chair



TR 9650 with stretcher

### TR Mobile Bath Lift System TR 9650

The TR 9650 Mobile Bath Lift System offers flexibility and is designed to easily convert into different configurations to accommodate a wide variety of needs in both the acute and long term care environment. Whether patients are in standing, seated or recumbent positions the TR 9650 provides a dignified complete solution for patients requiring aid getting in and out of bathtubs

#### Chair and stretcher version

Available as either a dedicated chair or stretcher version depending on the care needs (alternatively there is the Combi Lift)

#### Combi Lift

The unique design makes it possible to have both chair and stretcher option in one combined unit to meet all care needs. Attachable side parts makes conversion between the two options easy with no tools required

#### Seating and reclining surfaces

Seating and reclining surfaces are made of a soft, durable material that is non water absorbent, making it easy to clean and maintain and comfortable to sit and recline on

#### Height adjustment and movement

A smooth and quiet belt drive provides for safe and secure raising and lowering. Four twin castors, two with locking and two with straight steering, make the movement safe and stable

#### Chassis

A low and narrow chassis is designed for easy access under beds and baths for safe transfer

#### Safety

Ergonomically designed hand grips and safety belts are incorporated into the chair/stretcher to provide security and assurance to both the attendant and patient

The safety stop engages when the chair/stretcher is lowered onto any surfaces or obstacles

An integral autostop prevents the chair/stretcher from dropping if drive belt fails

#### Magnetic battery charger

A magnetic battery charger connection has been designed for easy connection and to prevent accidental damage

#### Durable

The stainless steel components ensure a long, functional and productive life

	TR 9650
Operating Height Range	200-965mm
Working Load Limit	150kg
Structure	Powder coated, zinc plated steel and stainless steel
Castors	Twin 100 mm castors, two with brakes and two with straight steering
Control	Foot control for height adjustment
Stretcher / Pillow	Flame retardant material (Grey)
Power Operation	Rechargeable battery 24 V



### A&D Hospital Chair Scale HVL-CS

Ergonomically designed chair scale ideal for hospital and aged care facilities to weigh patients with ease and accuracy

- Comfortable and easy to clean seat ensures maximum hygiene
- Highly visible LCD display
- Quick, accurate and easy to operate
- Full digital calibration ensures accuracy and simplicity
- Dual power supply (6 x D cell batteries, or optional AC adapter)
- Auto power off preserves battery life
- Quality safety wheels and brake levers to ensure patient safety
- Flip up foot plates
- Australian made and designed
- 1 year warranty

**Specifications:**  
Capacity : 150 kgs  
Resolution : 20 g  
Dimension : 750(W) x 630(D) x 880(H) mm



### A&D In-ground Weighing Scale

Improves the efficiency and safety of weighing bed bound or mobility challenged patients

- A pit mounted system that does not require removing patients from a stretcher or bed when weighing
- Eliminates the risk of incurring further injury, discomfort or inconvenience to patients, especially frail, elderly or bariatric patients
- Saves crucial time and double handling for staff
- Eliminates the potential OH&S issues for staff

**Specifications:**  
Capacity : 1000 kgs  
Resolution : 0.5 kg  
Dimension : 2000 x 1050 mm (as standard)



**A&D Budget Wellbeing Bathroom Scale UC-331**

Budget scale to suit your basic personal weighing use

- Transparent platform
- Stylish glass bathroom scale
- Liquid crystal display
- Displays in kg
- Long battery life
- Simple one touch operation
- 1 year warranty

**Specifications:**  
 Capacity : 150 kg  
 Resolution : 0.1 kg  
 Dimension : 310(W) x 310(D)



**A&D Patient Scale PW-200KGL**

Professional scale appearance ideal to suit healthcare environments. With high capacity and accuracy and easy operation

- High weighing capacity 220kgs
- High accuracy 20g increment is ideal for dietary assessment and weight management
- Accurate freeze display reading. Reading will "hold" until weight changes by 25% or greater
- No slip platform "Blue Feet" surface ensures a safe weighing surface
- Easy portability
- Flexible set up, column can be adjusted or removed from scale to suit your environment
- Powered from mains or by 6 x D cell batteries
- Standard data output
- Optional printer available\* *requires non standard model using KGV model*
- Australian Made
- 1 Year warranty

**Specifications:**  
 Capacity : 220 kgs  
 Resolution : 20 g  
 Dimension : 390(W) x 530(D) mm



**A&D Precision Scale for Personal Use UC-321, UC-321PL, UC-321PBT**

Personal scale designed for people who need to monitor weight PRECISELY! Ideal for:

- Weight watchers who needs to monitor their weight precisely
- People who want to know their class of weight (BMI calculation enables users to know their condition)
- Dialysis patients who need to maintain their weight within a small range
- Athletes who need to control their optimal weight for competition
- High capacity 150kgs - 200kgs (refer models below)
- Precise scale with fine resolution 50g - 100g (refer models below)
- Body Mass Index (BMI) calculation
- Memory storage allows to store up to 31 weights - ideal for weight loss monitoring
- Target weight setting
- Full digital calibration (FDC) ensuring accurate and simple calibration
- Clear large display
- Ultra low profile
- Rugged construction and sleek design
- Battery powered with one touch on/off switch
- Bluetooth communication (UC-321PBT only)
- 1 year warranty



UC-321



UC-321PL



UC-321PBT

	UC-321	UC-321PL	UC-321PBT
Capacity	150kgs	200kgs	200kgs
Resolution	50g	100g	100g
Dimension	310mm(W) x 310mm(D)		



**Chair Shower Commode Drop Arm**

AC12-3100-3005 (Open Front Seat)  
 AC12-3100-3004 (Closed Front Seat)

The Commode combines a manoeuvrable and stable construction with a durable, stainless steel manufacture

Designed and built to the rigorous Australian Standard, all models feature washable surfaces, soft padded seat, PVC backrest and 12.5mm diameter stainless steel and reinforced nylon castors

Flexible in design with user comfort and safety a primary consideration

Forward location of front wheels ensures stability even when the user leans forward. Stable when standing on the forward located foot plate

- 120 Kg capacity
- Soft padded seat (open or closed front)
- Drop arm
- Pan holder
- Sliding footrest with extra grip surface
- Wheels: 12.5cm standard with 2 locking
- 65(W)x110(H)x70(Front to Back) cm
- Australian Made



	Single Slim Line Linen Bag Trolley with Lid	Double Slim Line Linen Bag Trolley with Lid	Triple Slim Line Linen Bag Trolley with Lid
Product Code	FQ26-1645	FQ26-1655	FQ26-1680
Lid Type		With foot operated PVC lid	
Linen Skip Lids		FQ26-1681W - White	
		FQ26-1681R - Red	
		FQ26-1682B - Blue	
		FQ26-1683Y - Yellow	
		FQ26-1681G - Green	
Dimension	38 x 59.5 x 87 cm	76.5 x 59.5 x 87 cm	113 x 59.5 x 87 cm
* Please note Linen Bags are not supplied with Trolleys. Are available as optional extras			

Oxford EME designs and manufactures a range of high quality furniture and equipment for hospitals, medical centres, nursing homes and other healthcare facilities in the Australasian market. There are over 100 products in the range



Trolley Type	Instrument Trolley	Dressing Trolley- 1 drawer	Dressing Trolley- 2 drawers	30 dose Medication Trolley
Product Code	FA18-0250	FB18-0450- Stainless Steel FB55-0450- Powdercoated	FB18-0650- Stainless Steel FB55-0650- Powdercoated	FL55-4560
Rails	Rails on 3 sides (also available without rails)			
Drawer	N/A	1 x 12.5cm deep, full width and have double extension roller bearing slides	2 x 12.5cm deep full width and have double extension roller bearing slides	3 x 10cm & 1 x 25cm deep. Heavy duty drawers, full extension with 40kg capacity. Central locking, 3 Top drawers have removable divided aluminium compartments each with 3 dividers
Shelf	2 shelves with 48cm clearance	1 shelf 40cm clearance between drawer and lower shelf		1 Shelf 22cm clearance between drawer and lower shelf
Construction	Strong but light weight welded construction	Wrap around side panels have hygienic advantages minimising the number of exposed welds and joints as well as contributing to strength		Heavy duty drawers, full extension with 40kg capacity
Wheel Colour (Powdercoated Version)	Blue Weave	7.5cm diameter		12.5cm diameter with 2 locking
Material	Blue Weave	Blue Weave/Pearl White Drawers		
Finishing		Stainless Steel Satin finish		
Dimension	50 x 50 x 90 cm	100 x 50 x 90 cm	50 x 50 x 90 cm	60 x 50 x 90 cm

Please contact AIS Healthcare to discuss other options and configurations available



	Single Slim Line Linen Bag Trolley without Lid	Double Slim Line Linen Bag Trolley without Lid	Triple Slim Line Linen Bag Trolley without Lid
Product Code	FQ26-1605	FQ26-1615	FQ26-1670
Lid Type		With no lid	
Dimension	35 x 45 x 86 cm	72.5 x 45 x 86 cm	110 x 45 x 86 cm

\* Please note Linen Bags are not supplied with Trolleys. Are available as optional extras

## Care & Maintenance of Haycomp Lifters & Slings

The performance of your Haycomp lifters and slings depends on a number of factors including age, frequency and appropriateness of use, storage and cleaning procedures.

All slings manufactured for the Haycomp range of patient lifters have a 5 year life cycle, based on correct use and care. We recommend slings be replaced 5 years after the manufacture date to ensure patient safety.

A regular inspection of sling clips, material condition, stitching, straps, velcro and foam inserts should take place. Sling clips need to be load tested to ensure each clip continues to meet the safe working load it was manufactured and tested to.

An annual sling safety audit is the ideal way to ensure the safety of your slings for patient use.

AIS Healthcare provides full service support for the Haycomp range of patient lifters and slings with our 11 point safety check. To book a service or for further information, contact AIS Healthcare on the details below.



### AIS Healthcare Pty Ltd

1 & 2, 21 Stud Road  
Bayswater, VIC 3153

[www.aishealthcare.com.au](http://www.aishealthcare.com.au)

email: [sales@aishealthcare.com.au](mailto:sales@aishealthcare.com.au)

Tel : (03) 9729 9399

Fax: (03) 9720 5776

October 2013